



US009281494B2

(12) **United States Patent**  
**Lee et al.**

(10) **Patent No.:** **US 9,281,494 B2**  
(45) **Date of Patent:** **Mar. 8, 2016**

(54) **DISPLAY DEVICE AND ORGANIC LIGHT  
EMITTING DIODE DISPLAY**

(75) Inventors: **Choong-Ho Lee**, Yongin (KR); **Kie  
Hyun Nam**, Yongin (KR); **Jung-Min  
Lee**, Yongin (KR)

(73) Assignee: **SAMSUNG DISPLAY CO., LTD.**,  
Yongin, Gyeonggi-Do (KR)

7,538,488	B2 *	5/2009	Kwak	313/506
2002/0125484	A1	9/2002	Silvernail et al.	
2003/0168966	A1 *	9/2003	Kobayashi et al.	313/495
2004/0232833	A1 *	11/2004	Menda et al.	313/512
2005/0036090	A1 *	2/2005	Hayashi et al.	349/122
2008/0242787	A1 *	10/2008	Kim et al.	524/450
2008/0303140	A1	12/2008	Ohtani et al.	
2009/0065590	A1 *	3/2009	Aoki et al.	235/492
2009/0108738	A1 *	4/2009	Kwak	313/504
2009/0224663	A1 *	9/2009	Inoue et al.	313/504
2010/0013372	A1	1/2010	Oikawa et al.	

(\*) Notice: Subject to any disclaimer, the term of this patent is extended or adjusted under 35 U.S.C. 154(b) by 306 days.

(21) Appl. No.: **13/064,721**

(22) Filed: **Apr. 11, 2011**

(65) **Prior Publication Data**

US 2012/0026074 A1 Feb. 2, 2012

(30) **Foreign Application Priority Data**

Jul. 29, 2010 (KR) ..... 10-2010-0073513

(51) **Int. Cl.**

**H01L 51/52** (2006.01)

**H01L 27/32** (2006.01)

(52) **U.S. Cl.**

CPC ..... **H01L 51/5237** (2013.01); **H01L 27/3276**  
(2013.01); **H01L 51/5246** (2013.01)

(58) **Field of Classification Search**

CPC ..... H01L 27/3276; H01L 51/5237; H01L  
51/5246

USPC ..... 345/76, 173-183; 313/495, 503, 504,  
313/506, 511, 512

See application file for complete search history.

(56) **References Cited**

**U.S. PATENT DOCUMENTS**

6,998,776 B2 2/2006 Aitken et al.  
7,537,504 B2 5/2009 Becken et al.

**FOREIGN PATENT DOCUMENTS**

CN	1496543	A	5/2004
CN	1575048	A	2/2005
EP	1 835 333	B1	2/2009
JP	10-091095		4/1998
JP	2001-052858		2/2001
JP	2001-133761		5/2001
JP	2005-338419		12/2005
JP	2008-186618		8/2008
KR	10-2003-0083528	A	10/2003
KR	10-2006-0065367	A	6/2006
KR	10-2007-0033702	A	3/2007
KR	10-2008-0088031	A	10/2008

\* cited by examiner

*Primary Examiner* — Kumar Patel

*Assistant Examiner* — Insa Sadio

(74) *Attorney, Agent, or Firm* — Lee & Morse, P.C.

(57) **ABSTRACT**

A display device includes: a display substrate; a display unit formed on the display substrate and a sealing substrate affixed to the display substrate by an adhering layer that surrounds the display unit. The sealing substrate includes a composite member including a resin and a plurality of carbon fibers and an insulating member attached to the composite member. The insulating member includes a through hole. A metal film is disposed at one side of the sealing substrate, facing the display substrate; and a conductive connection portion contact the metal film through the through hole.

**29 Claims, 18 Drawing Sheets**

**100**

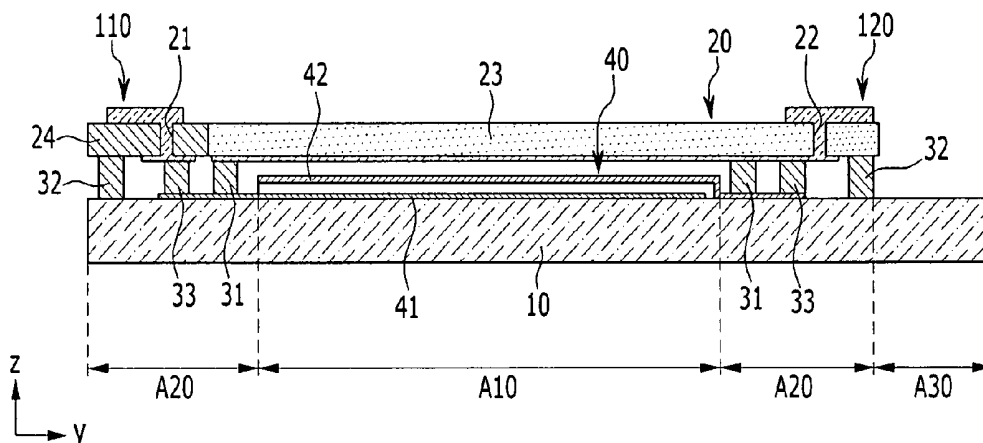

FIG. 1

100

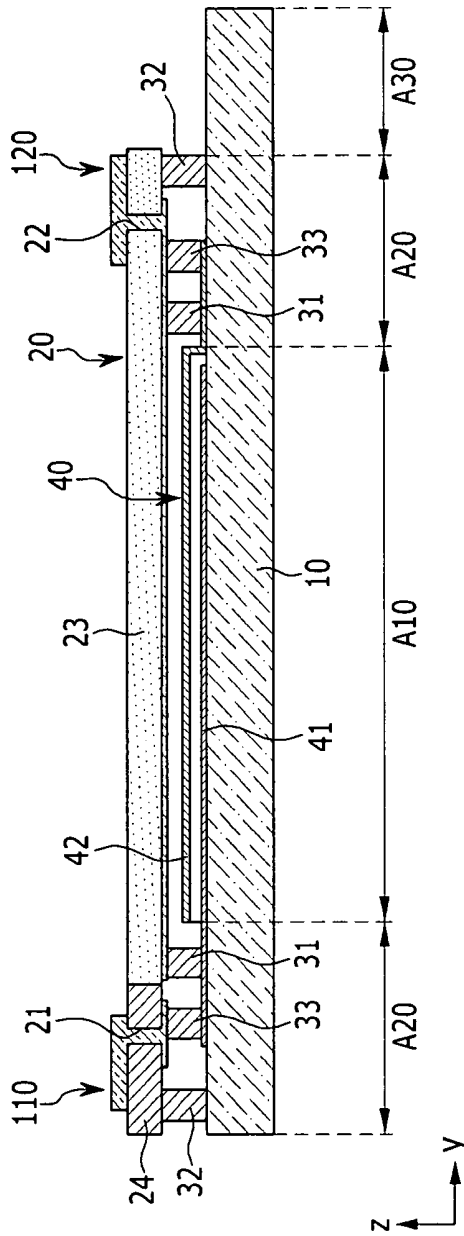

FIG. 2

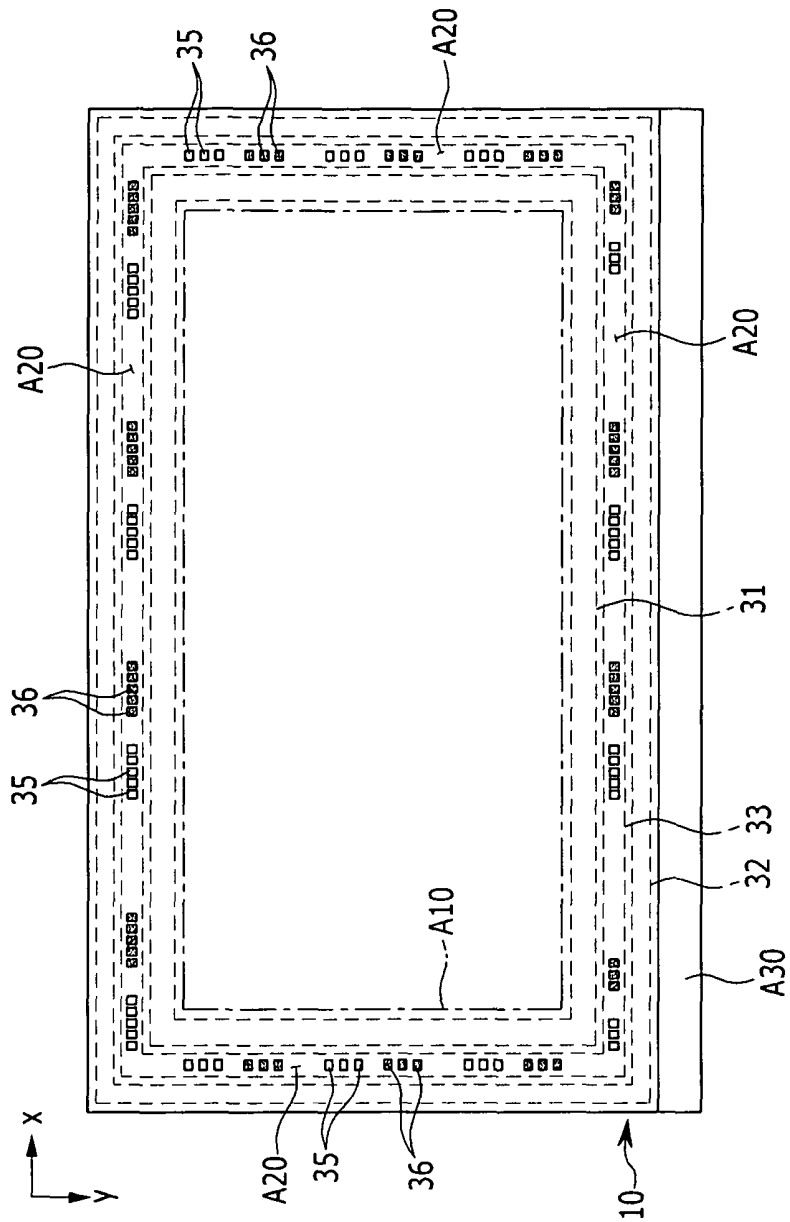

FIG. 3

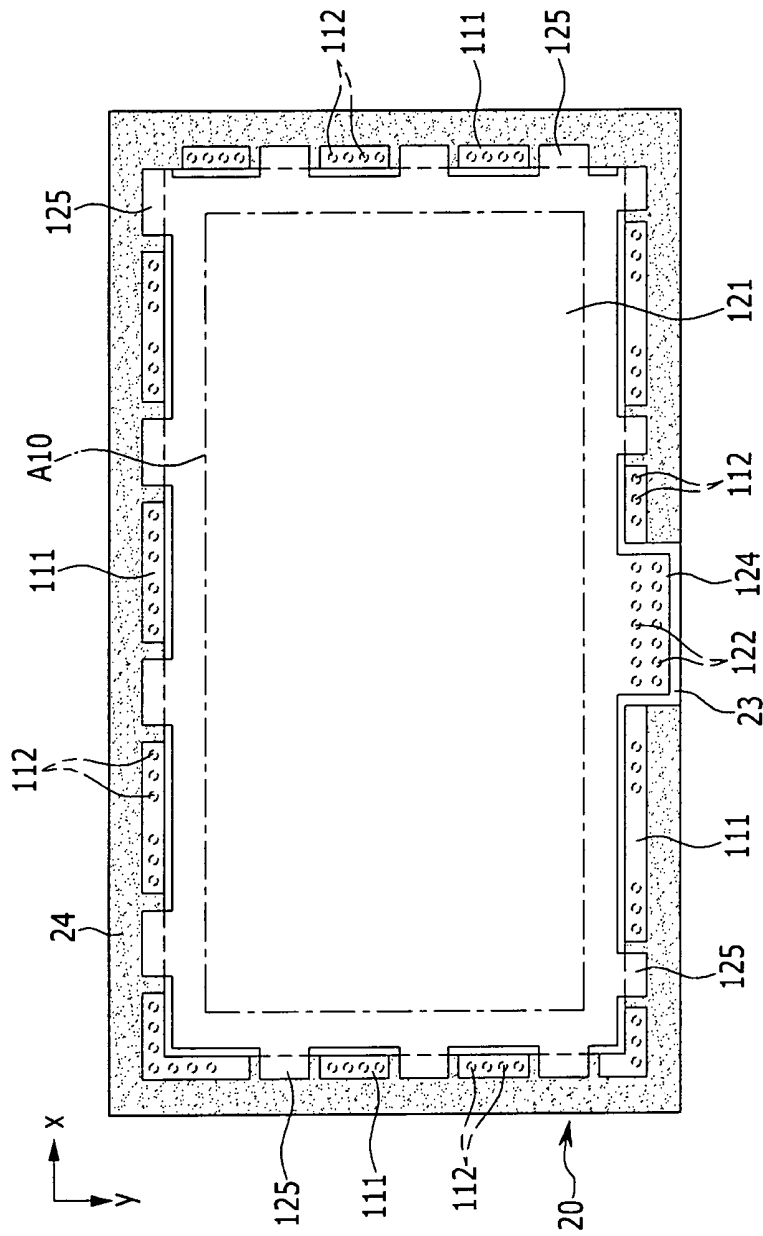

FIG. 4

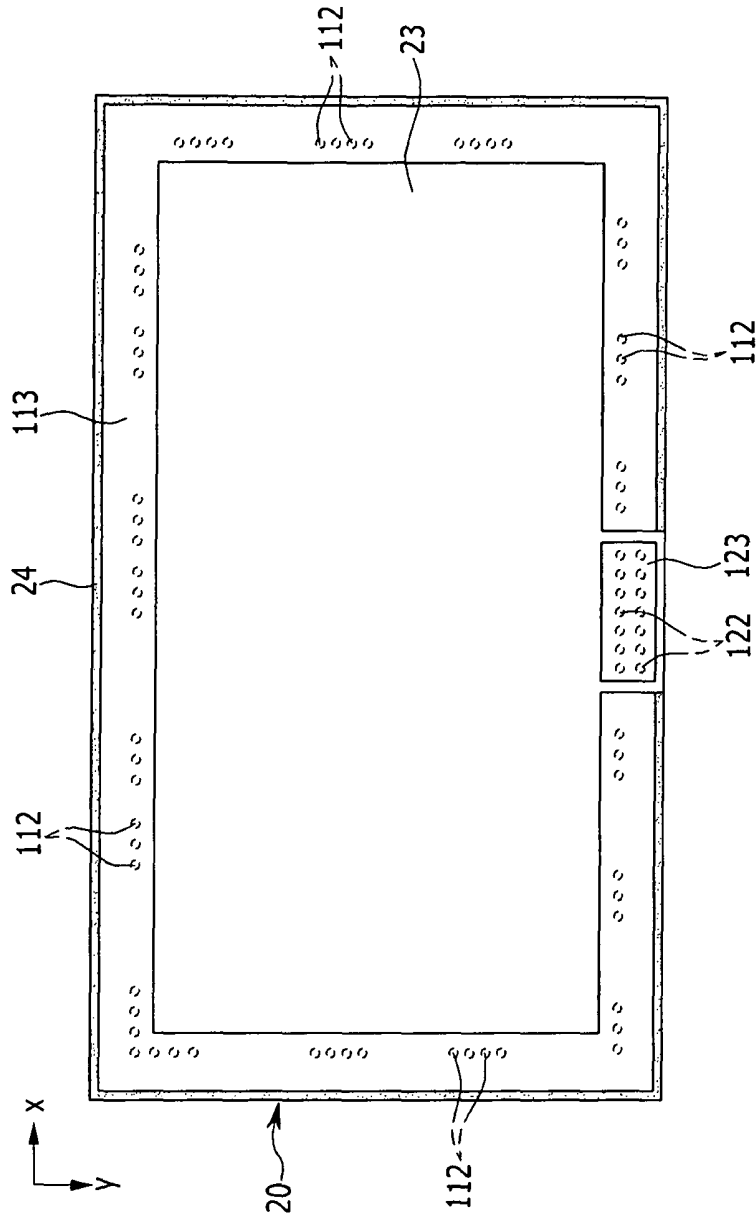

FIG. 5

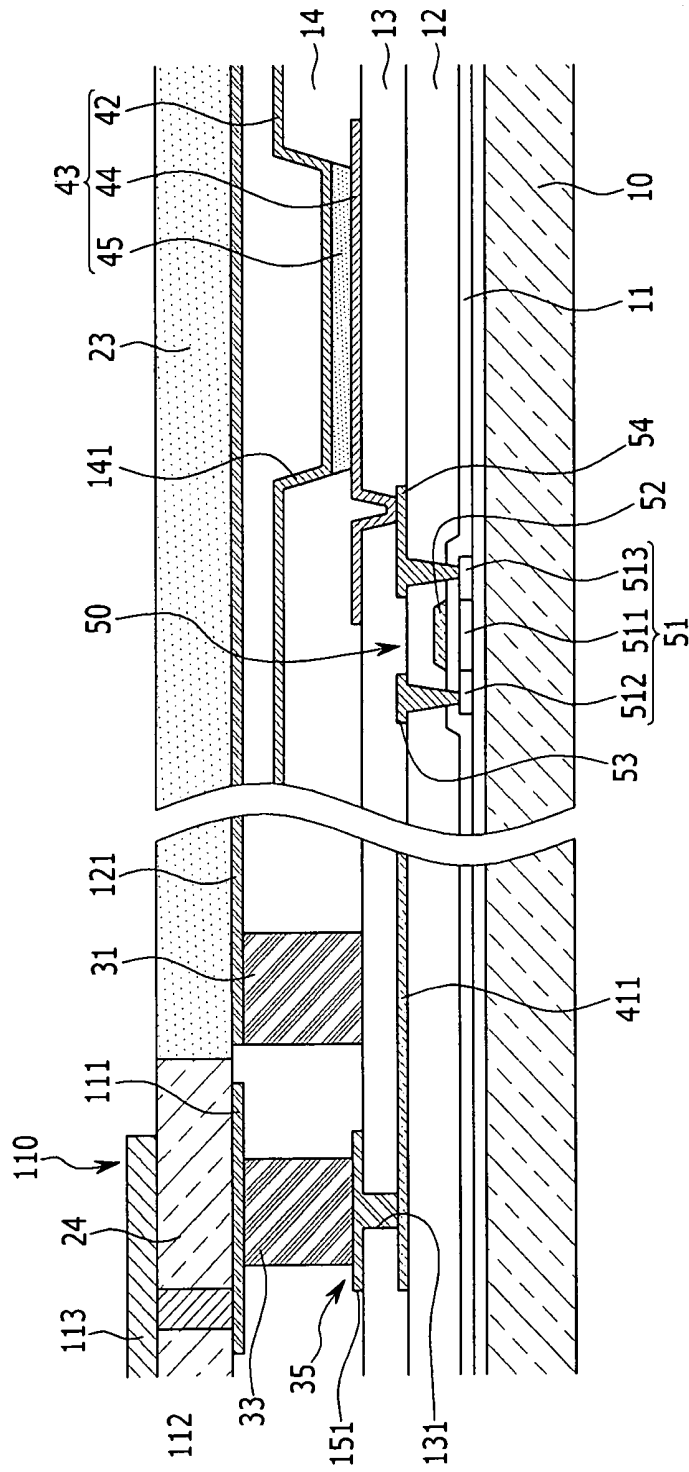

FIG. 6

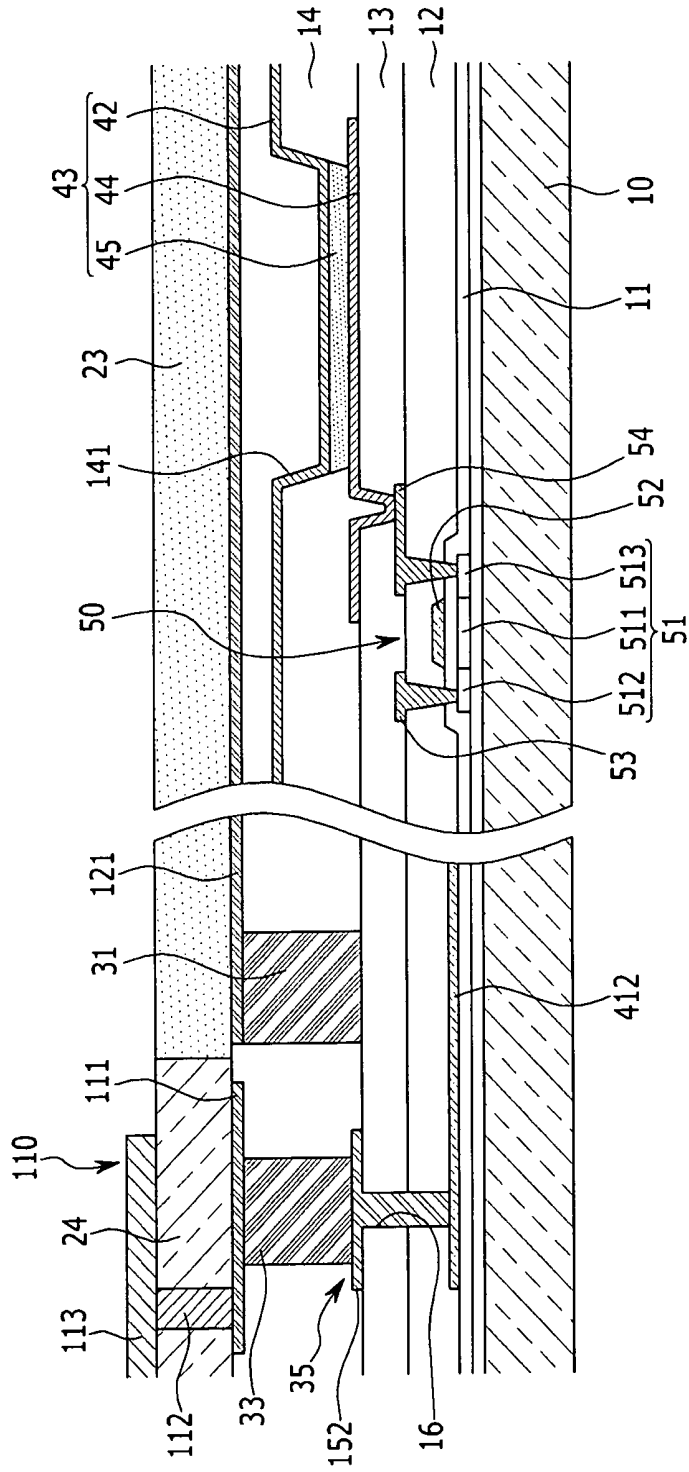

FIG. 7

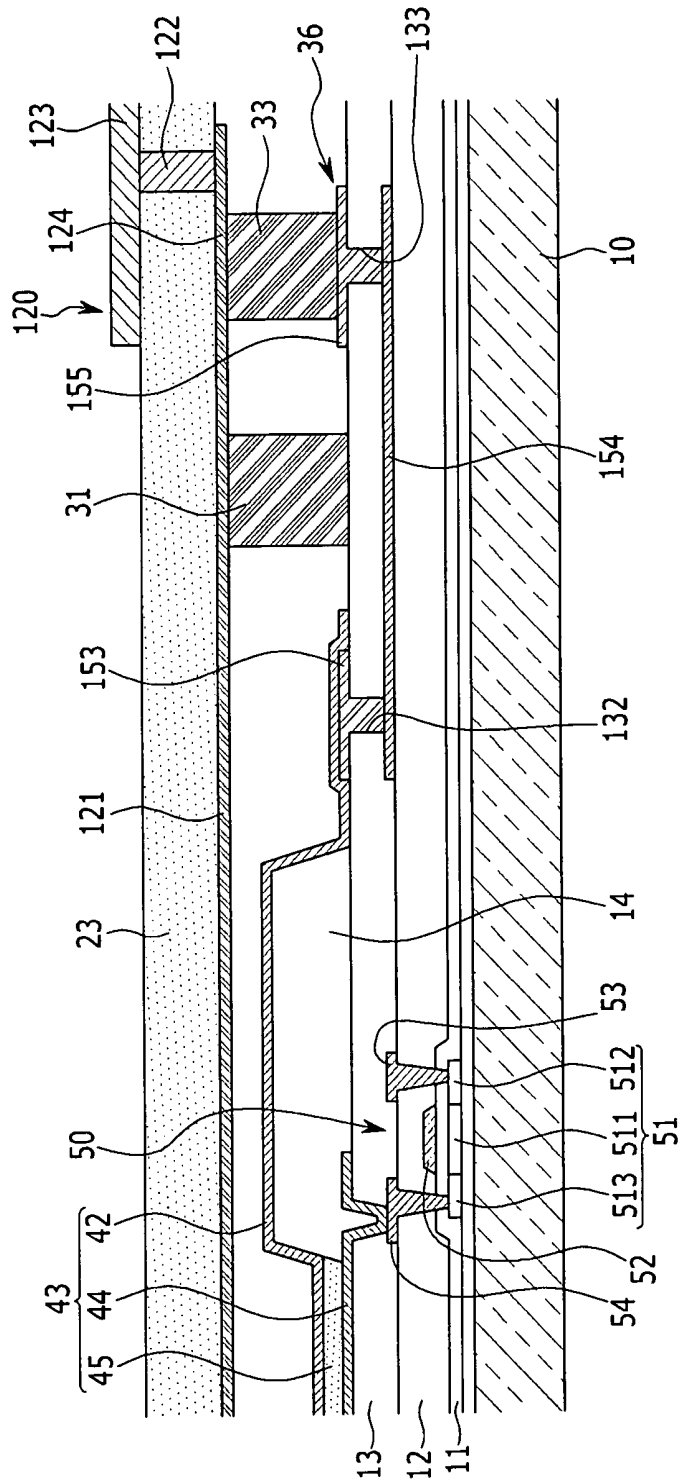

FIG. 8

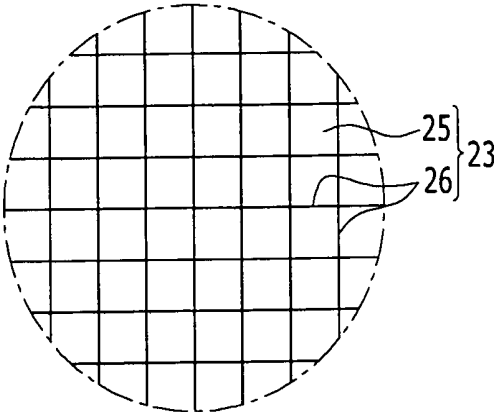

FIG. 9

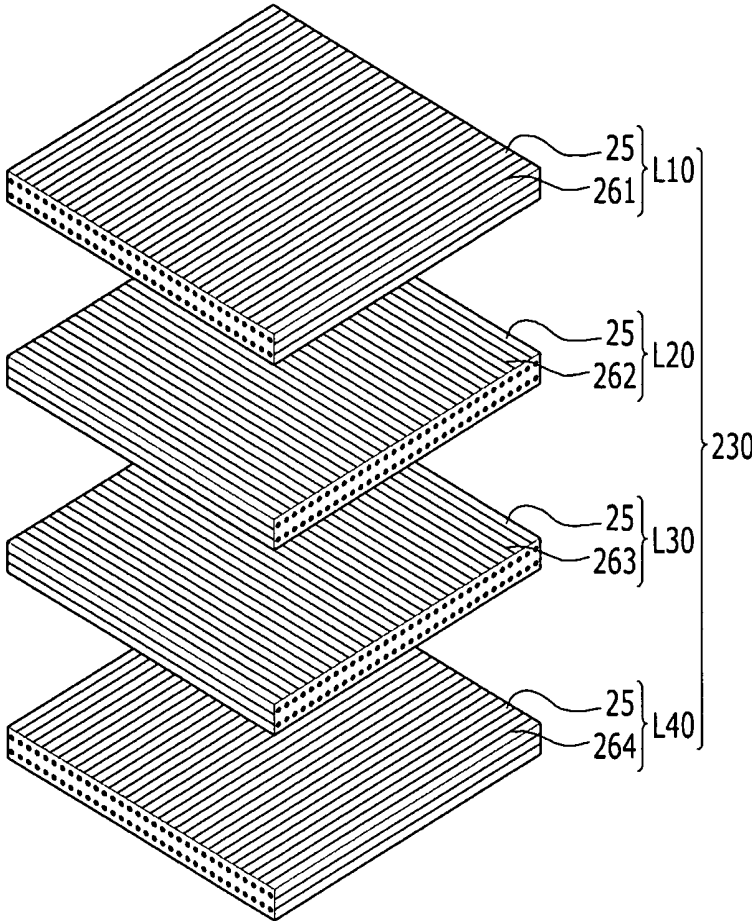

FIG. 10

200

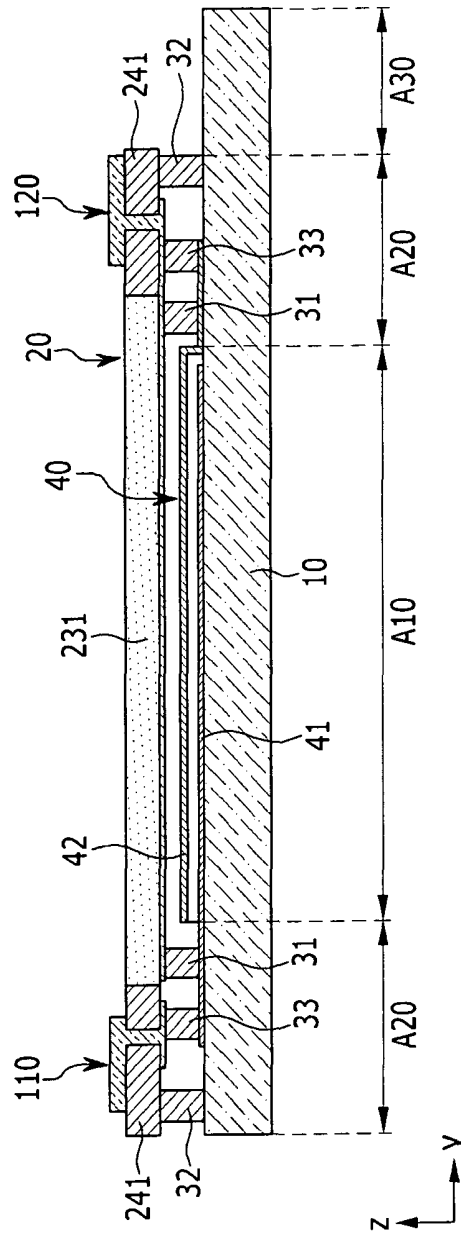

FIG. 11

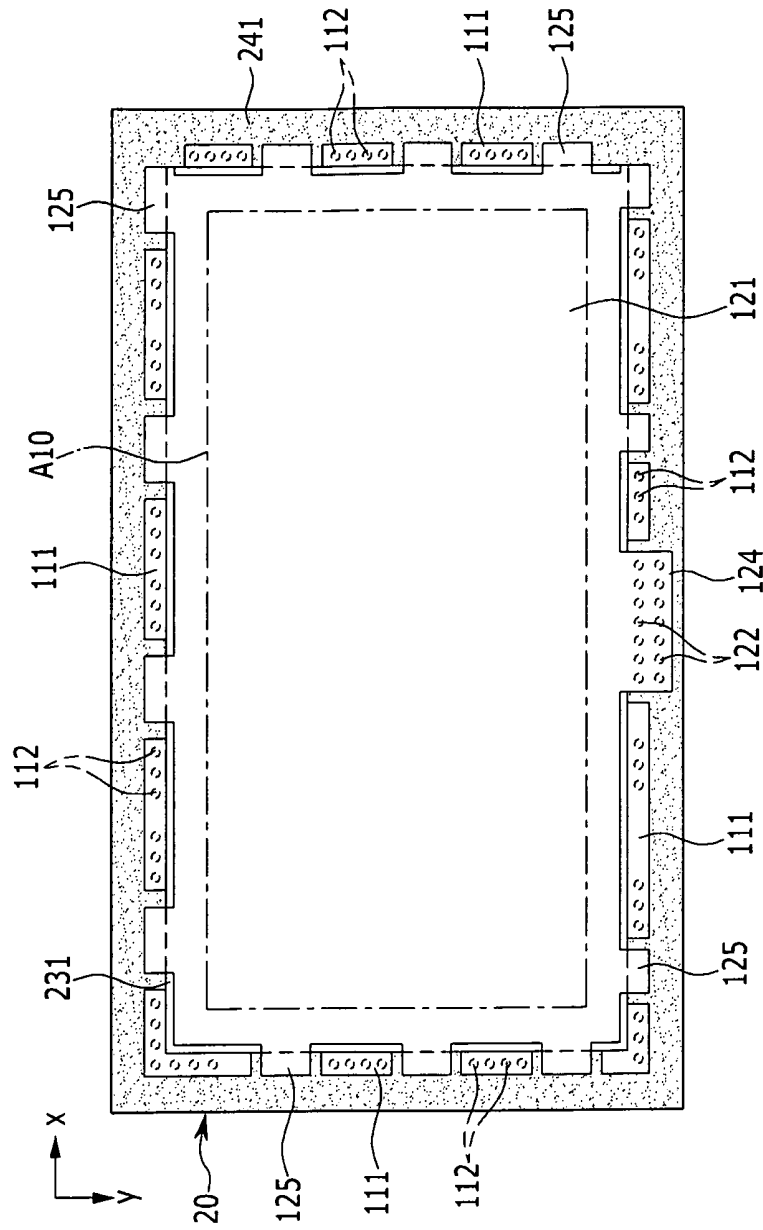

FIG. 12

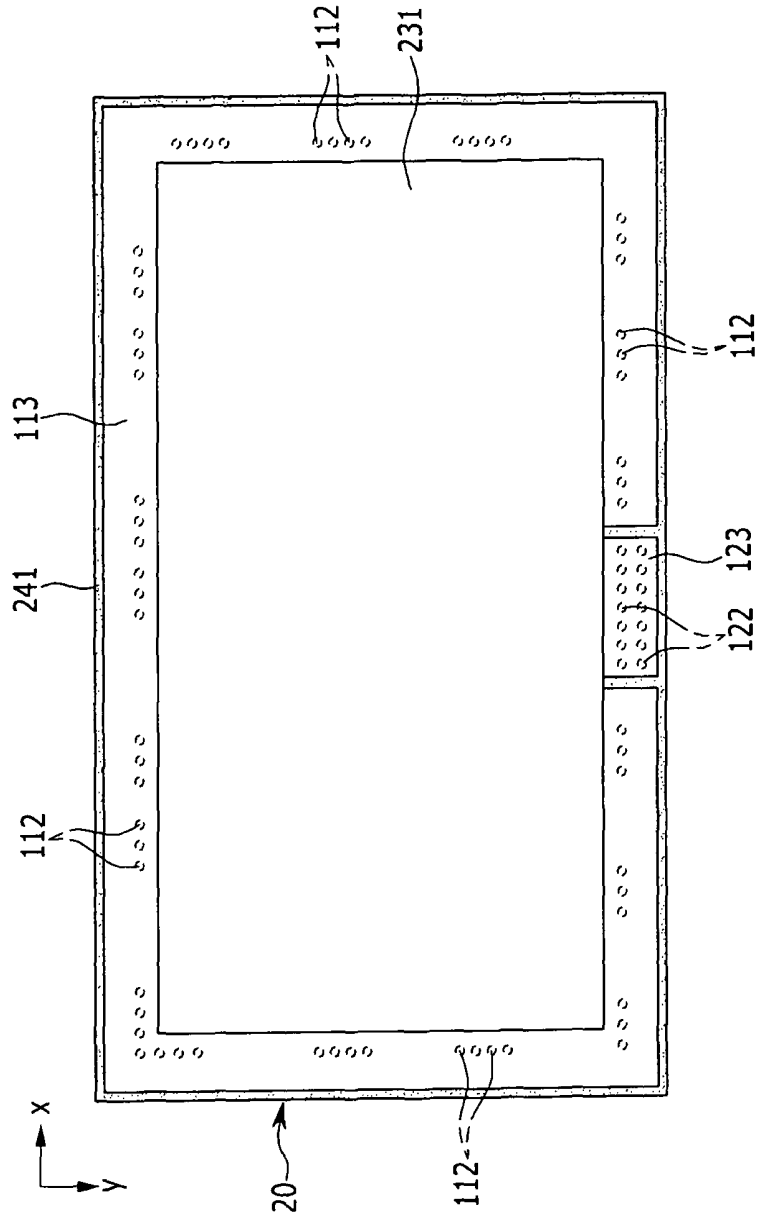

FIG. 13

300

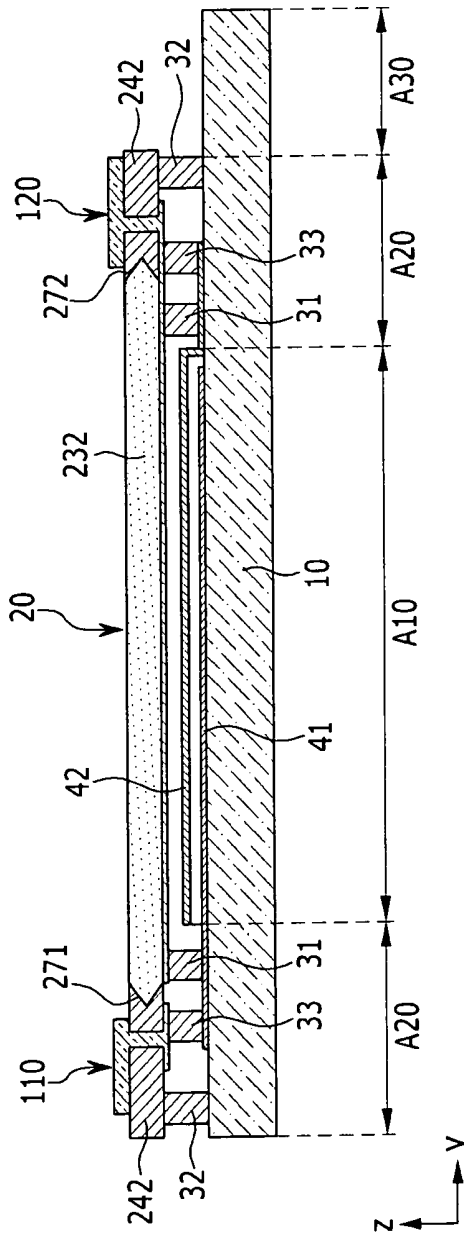

FIG. 14

400

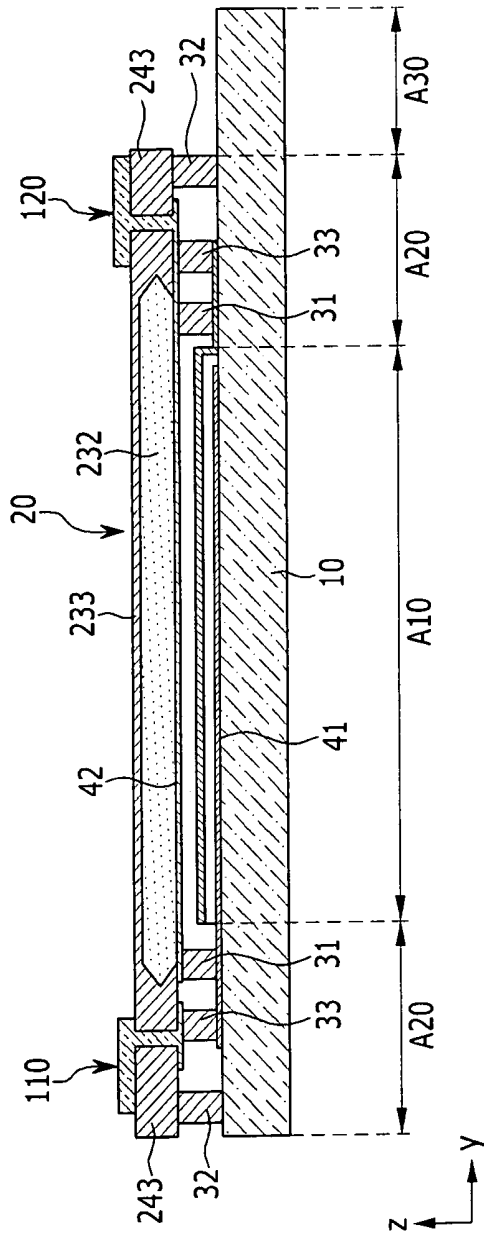

FIG. 15

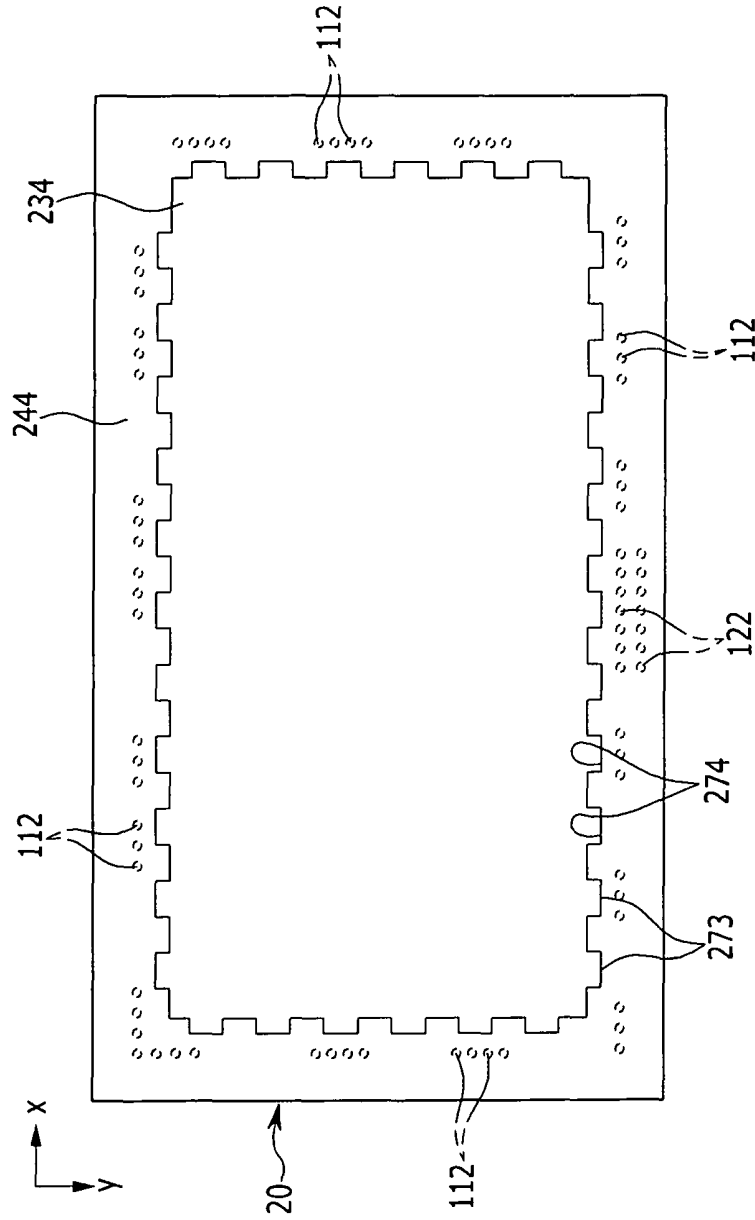

FIG. 16

600

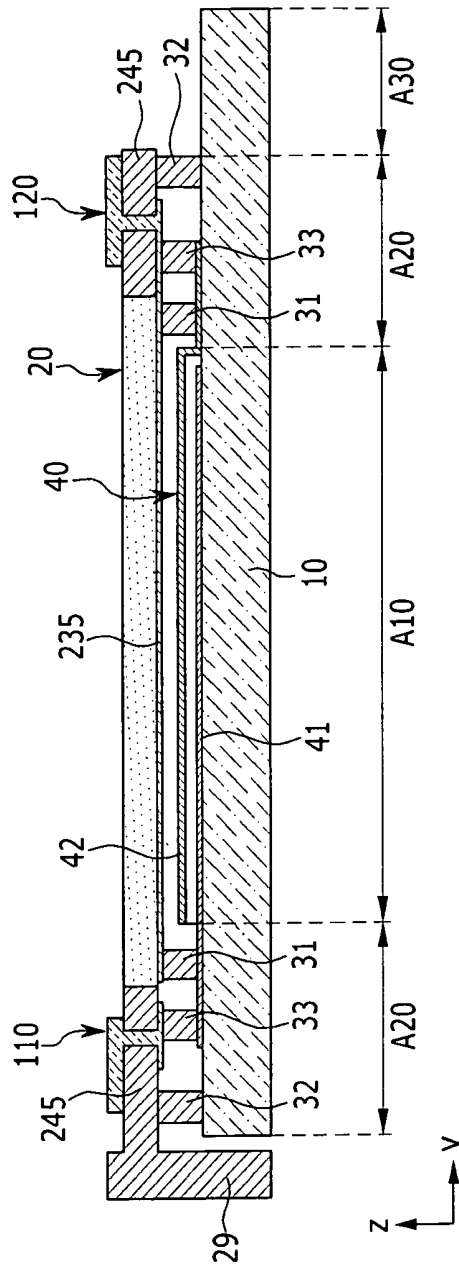

FIG. 17

700

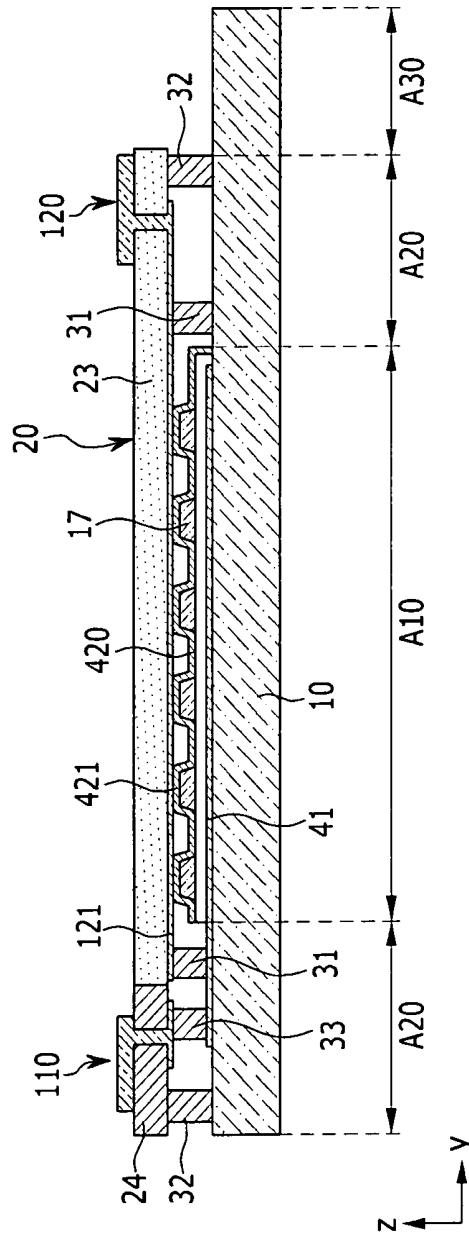
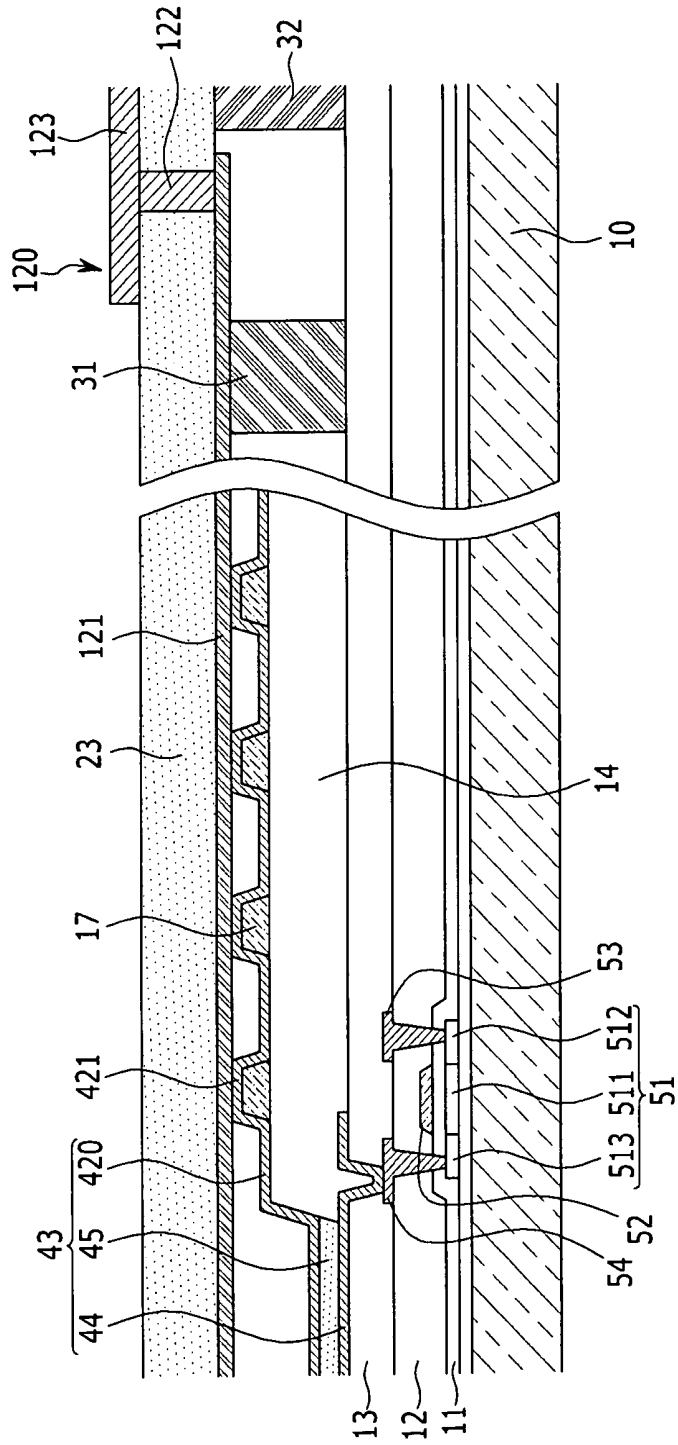

FIG. 18



## DISPLAY DEVICE AND ORGANIC LIGHT EMITTING DIODE DISPLAY

### BACKGROUND

#### 1. Field

The described technology relates generally to a display device. More particularly, the described technology relates generally to an organic light emitting diode (OLED) display. In addition, the described technology relates generally to a sealing substrate that seals a display unit.

#### 2. Description of the Related Art

A display device includes a self-emissive organic light emitting diode (OLED) display formed in a plate shape. The OLED display is provided with an organic light emitting element that emits light to display an image.

The above information disclosed in this Background section is only for enhancement of understanding of the background of the described technology and therefore it may contain information that does not form the prior art that is already known in this country to a person of ordinary skill in the art.

### SUMMARY

According to an embodiment, there is provided a display device including: a display substrate, a display unit disposed on the display substrate, a sealing substrate affixed to the display substrate by an adhering layer that surrounds the display unit, the sealing substrate including a composite member including a resin and a plurality of carbon fibers and an insulating member affixed to the composite member, the insulating member including at least one through hole, a metal film disposed at one side of the sealing substrate, facing the display substrate, and a conductive connection portion contacting the metal film through at least one through hole.

The carbon fibers may cross each other in the resin.

The composite member may include a plurality of layers, each of the plurality of layers including a resin and a plurality of carbon fibers, wherein a plurality of carbon fibers arranged in at least one of the plurality of layers and a plurality of carbon fibers arranged in at least another layer among the plurality of layers cross each other.

The insulating member may be affixed to the composite member at a peripherally outward side of at least three peripheral edges of the composite member. The at least one through hole may include a plurality of first through holes through the insulating member. The composite member may include a plurality of second through holes.

The display device may further include a first conductive portion extending between inner and outer sides of the insulating member through the plurality of first through holes and receiving a first electric signal, and a second conductive portion extending between inner and outer sides of the composite member through the plurality of second through holes and receiving a second electric signal.

The insulating member may be affixed to the composite member at a peripherally outward side of all peripheral edges of the composite member. The at least one through hole may include a plurality of first through holes and a plurality of second through holes.

The display device may further include a first conductive portion extending between inner and outer sides of the insulating member through the plurality of first through holes and receiving a first electric signal, and a second conductive portion extending between an inner side of the insulating member, an inner side of the composite member, and an outer side

of the insulating member through the plurality of second through holes and receiving a second electric signal.

The composite member may include a protrusion at a side surface that faces the insulating member, and the insulating member may include a groove receiving the protrusion.

The composite member may include a plurality of protruding portions spaced apart from each other at a side surface facing the insulating member, and the insulating member may include a plurality of recess portions receiving the protruding portions.

The insulating member further may include an insulating plate covering an external surface of the composite member.

The insulating member further may include a protection portion that protectively covers the adhering layer and a side surface of the display substrate.

The insulating member may be a plastic injection molded material.

The insulating member may include a negative thermal expansion filler.

The metal film may include at least one of an aluminum film, an aluminum alloy film, a copper film, and a copper alloy film.

According to an embodiment, there is provided an organic light emitting diode (OLED) display including a display substrate, a display unit disposed on the display substrate and including a common power line and a common electrode, a sealing substrate affixed to the display substrate by at least one adhering layer that surrounds the display unit, the sealing substrate including first and second through holes, a first conductive portion disposed on inner and outer sides of the sealing substrate and extending through the first through holes, the first conductive portion supplying a first electric signal to the common power line, and a second conductive portion disposed on the inner and outer sides of the sealing substrate and extending through the second through holes, the second conductive portion supplying a second electric signal to the common electrode, wherein the sealing substrate includes, a composite member including a resin and a plurality of carbon fibers, and an insulating member attached to the composite member and including at least one through hole among the first and second through holes.

The OLED display may further include a pad unit disposed peripherally outward from the display unit, and including a first pad connected with the common power line and a second pad connected with the common electrode, and a conductive adhering layer disposed between the first pad and the first conductive portion and between the second pad and the second conductive portion.

The common power line may include a first common power line and a second common power line that cross each other, and wherein the pad unit includes a plurality of the first pad and the second pad iteratively alternated along one direction of the display substrate.

The conductive adhering layer may be electrically conductive in the thickness direction and electrically insulating in directions other than the thickness direction.

The OLED display may further include a first pad disposed at an outer side of the display unit and a conductive adhering layer disposed between the first pad and the first conductive portion. The second conductive portion may be directly attached to the common electrode.

The OLED display may further include a plurality of spacers disposed at a lower portion of the common electrode. The common electrode may include protruding portions corresponding to the spacers and contacting the second conductive portion.

The insulating member may be attached to the composite member at peripherally outward sides of at least three peripheral edges of the composite member, and wherein the insulating member includes the plurality of first through holes, and the composite member includes the plurality of second through holes.

The first conductive portion may include a first inner layer disposed at the inner side of the insulating member, a first connection portion extending through the first through hole, and a first outer layer disposed at the outer side of the insulating member. The second conductive portion may include a second inner layer formed at the inner side of the composite member, a second connection portion filled in the second through hole, and a second outer layer formed at the outer side of the composite member.

The insulating member may be attached to the composite member at a peripherally outward side of the edges of the composite member. The insulating member may include the first and second through holes.

The first conductive portion may include a first inner layer at the inner side of the insulating member, a first connection portion that fills the first through hole, and a first outer layer at the outer side of the insulating member. The second conductive portion may include a second inner layer at the inner side of the insulating member and the inner side of the composite member, a second connection portion that fills the second through hole, and a second outer layer at the outer side of the insulating member.

The second inner layer may include a metal foil having an oxide film formed by anodizing at one side thereof, facing the composite member.

The insulating member may be made of a plastic injection molded material.

The insulating member may include a negative thermal expansion filler.

The composite member may include a protrusion at a side surface thereof, facing the insulating member. The insulating member may include a groove that receives the protrusion.

The composite member may include a plurality of protruding portions spaced apart from each other at a side surface, facing the insulating member and the insulating member may include recess portions receiving the protruding portions.

The insulating member may further include an insulating plate covering an external surface of the composite member.

The insulating member may further include a protection portion covering the adhering layer and the display substrate.

#### BRIEF DESCRIPTION OF THE DRAWINGS

The above and other features and advantages will become more apparent to those of ordinary skill in the art by describing in detail exemplary embodiments with reference to the attached drawings, in which:

FIG. 1 illustrates a schematic cross-sectional view of an organic light emitting diode (OLED) display according to an exemplary embodiment.

FIG. 2 illustrates a top plan view of a substrate of the OLED display of FIG. 1.

FIG. 3 illustrates a top plan view of a sealing substrate of the OLED display of FIG. 1.

FIG. 4 illustrates a top plan view of an external surface of the sealing substrate of the OLED display of FIG. 1.

FIG. 5 to FIG. 7 illustrate partially enlarged cross-sectional views of the OLED display according to the exemplary embodiment of FIG. 1.

FIG. 8 illustrates a partially enlarged top plan view of a composite member of the OLED display of FIG. 1.

FIG. 9 relates to an exemplary variation of FIG. 8, illustrating an exploded perspective view of the composite member of the OLED display of FIG. 1.

FIG. 10 illustrates a schematic cross-sectional view of an OLED display according to another exemplary embodiment.

FIG. 11 illustrates a top plan view of an inner surface of a sealing substrate of the OLED display of FIG. 10.

FIG. 12 illustrates a top plan view of an outer surface of the sealing substrate of the OLED display FIG. 10.

FIG. 13 illustrates a schematic cross-sectional view of an OLED display according to another exemplary embodiment.

FIG. 14 illustrates a schematic cross-sectional view of an OLED display according to another exemplary embodiment.

FIG. 15 illustrates a top plan view of an outer surface of a sealing substrate of an OLED display according to another exemplary embodiment.

FIG. 16 illustrates a schematic cross-sectional view of an OLED display according to another exemplary embodiment.

FIG. 17 illustrates a schematic cross-sectional view of an OLED display according to another exemplary embodiment.

FIG. 18 illustrates a partially enlarged view of the OLED display of FIG. 17.

#### DETAILED DESCRIPTION

Korean Patent Application No. 10-2010-0073513, filed on Jul. 29, 2010, in the Korean Intellectual Property Office, and entitled: "Display Device and Organic Light Emitting Diode Display," is incorporated by reference herein in its entirety.

Example embodiments will now be described more fully hereinafter with reference to the accompanying drawings; however, they may be embodied in different forms and should not be construed as limited to the embodiments set forth herein. Rather, these embodiments are provided so that this disclosure will be thorough and complete, and will fully convey the scope of the invention to those skilled in the art.

In the drawing figures, the dimensions of layers and regions may be exaggerated for clarity of illustration. It will also be understood that when a layer or element is referred to as being "on" another layer or substrate, it can be directly on the other layer or substrate, or intervening layers may also be present. Further, it will also be understood that when a layer is referred to as being "between" two layers, it can be the only layer between the two layers, or one or more intervening layers may also be present. Like reference numerals refer to like elements throughout.

Herein, unless otherwise specified, terms such as "conductive" and "insulating" refer to electrical conductivity and insulation.

Herein, unless otherwise specified, the terms "inner" and "outer" refer to respective directions toward or away from a center of a described display and perpendicular to a plane of the described display (for example, in the direction of the Z-axis shown in FIGS. 1, 10, 13-14 and 16-17). The terms "peripherally inward" and "peripherally outward" refer to respective directions toward or away from a center of a described display in a plane of the described display (for example, in the plane defined by the X-Y-axes shown in FIGS. 2-4, 11, 12, and 15).

FIG. 1 illustrates a schematic cross-sectional view of an organic light emitting diode (OLED) display according to a first exemplary embodiment.

Referring to FIG. 1, an OLED display 100 according to the first exemplary embodiment includes a substrate 10, a display unit 40 formed in the substrate 10, and a sealing substrate 20 fixed to the substrate 10 by adhering layers 31 and 32 surrounding the display unit 40. The substrate 10 includes a

display area A10, where the display unit 40 is located, and a non-display area peripherally outward from the display area A10. The non-display area may be divided into wires, a sealing area A20, and a pad area A30.

The display unit 40 includes a plurality of pixels, and an organic light emitting element 43 and a driving circuit are formed in each pixel (see, for example, FIGS. 5 to 7). The organic light emitting element 43 includes a pixel electrode 44, an organic emission layer 45, and a common electrode 42. The driving circuit is formed of at least two thin film transistors including a switching thin film transistor and a driving thin film transistor 51, and at least one capacitor.

In addition, gate lines, data lines, and common power lines 41 are arranged in each pixel. The gate line transmits a scan signal and the data line transmits a data signal. The common power line 41 applies a common voltage to the driving thin film transistor 51. The common power line 41 may be parallel with the data line, or may be formed of a first common power line that is parallel with the data line and a second common power line that is parallel with the gate line.

A detailed description of the display unit 40 will be described below. FIG. 1 schematically illustrates the display unit 40 where the common power line 41 and the common electrode 42 are formed.

The adhering layers 31, 32 include a first adhering layer 31 surrounding the display unit 40 and a second adhering layer 32 located externally or peripherally outward from the first adhering layer 31. In addition, a conductive adhering layer 33 may be disposed between the first adhering layer 31 and the second adhering layer 32. The first adhering layer 31 and the second adhering layer 32 may be non-conductive, and may include an inorganic material, such as a glass frit, and a resin. The resin may include a thermosetting resin, such as, for example, an epoxy resin, polyurethane resin, phenol resin, melamine resin, and unsaturated polyester resin. Meanwhile, the material of the first adhering layer 31 and the second adhering layer is not limited thereto, so far as the material can seal or affix the substrate 10 and the sealing substrate 20 at a location peripherally inward from the first adhering layer 31.

In the above-stated OLED display 100, the common power line 41 and the common electrode 42 are not connected with a flexible printed circuit (not shown) attached to the pad area A30. The common power line 41 is connected with a first conductive portion 110 formed in the sealing substrate 20 and receives a first electric signal therefrom, and the common electrode 42 is connected with a second conductive portion 120 formed in the sealing substrate 20 and receives a second electric signal therefrom.

Thus, the OLED display 100 can evenly apply the corresponding electric signal to the common power line 41 and the common electrode 42 without forming the pad areas A30 at four edges (up, down, right, and left) of the substrate 10, while providing a large-sized display unit 40. As a result, the entire structure and the manufacturing process of the OLED display 100 can be simplified while providing a large-sized display unit 40 in which luminance non-uniformity may be prevented.

FIG. 2 illustrates a top plan view of a substrate of the OLED display of FIG. 1.

Referring to FIG. 1 and FIG. 2, a substrate 10 may be rectangular shaped with a pair of long sides and a pair of short sides. The wires and sealing areas A20 may be located peripherally outward from the four edges of the display area A10. In

the wires and the sealing area A20, the first adhering layer 31, the conductive adhering layer 33, and the second adhering layer 32 may be located.

In addition, the pad area A30 may be located at one of the edges of the substrate 10 peripherally outward from the wires and the sealing area A20. Although FIG. 2 illustrates that the pad area A30 is located at the lower long side of the substrate 10, the location of the pad area A30 is not limited thereto.

A first pad 35 electrically connected with the common power line 41 of the display unit 40 and a second pad 36 electrically connected with the common electrode 42 of the display unit 40 may be located in the wires and sealing area A20. A plurality of first pads 35 and second pads 36 may be formed at the four wires and sealing areas A20, and the first pads 35 and the second pads 36 may be iteratively alternated along a horizontal direction (x-axis direction in the drawing) and a vertical direction (y-axis direction in the drawing) of the substrate 10.

In FIG. 2, the second pad 36 is illustrated with a dot pattern and the first pad 35 is illustrated without a dot pattern in order to distinguish between the first pad 35 and the second pad 36. Among the plurality of first pads 35, first pads 35 that are located at the long side of the substrate 10 may be electrically connected with the first common power line, and first pads 35 located at the short side of the substrate 10 may be electrically connected with the second common power line. However, FIG. 2 exemplarily shows the locations and the number of first and second pads 35 and 36, and the illustrated locations and numbers are not restrictive.

The first pad 35 and the second pad 36 are formed at locations corresponding to the conductive adhering layer 33 in the wire and sealing area A20. The conductive adhering layer 33 may be provided to be conductive only in the thickness direction (z-axis direction of the drawing) and non-conductive in directions other than the thickness direction. Accordingly, a short circuit between the first pad 35 and the second pad 36 may be avoided even though one conductive adhering layer 33 contacts both the first pad 35 and the second pad 36.

A conductive adhering layer 33 having conductivity in all directions may be used. In this case, the conductive adhering layer 33 may be divided into a first conductive adhering layer (not shown) located corresponding to the first pad and a second conductive adhering layer (not shown) located corresponding to the second pad. In this case, the first conductive adhering layer and the second conductive adhering layer may be separated from each other with a predetermined distance in order to prevent short-circuit therebetween.

FIG. 3 and FIG. 4 illustrate top plan views of inner and outer surfaces of the sealing substrate in the OLED display of FIG. 1.

Referring to FIG. 1 to FIG. 4, the sealing substrate 20 may be formed in a size that covers the display area A10 and the four wires and sealing areas A20. Thus, the pad area A30 of the substrate 10 may be exposed to the outside without being overlapped with the sealing substrate 20.

The sealing substrate 20 may include a first through hole 21 through which a first electric signal of the common power line 41 may be applied and a second through hole 22 through which a second electric signal of the common electrode 42 may be applied. In addition, a first conductive portion 110 may extend over the inner surface of the sealing substrate 20, through the first through hole 21, and over the outer surface of the sealing substrate 20. A second conductive portion 120 may extend over the inner surface of the sealing substrate 20, through the second through hole 22, and over the outer surface of the sealing substrate 20.

The sealing substrate **20** may be formed of a composite member **23** and an insulating member **24** affixed to the external side of the composite member **23**. The composite member **23** may include a resin and a plurality of carbon fibers. The first through hole **21** and the first conductive portion **110** may be formed in the insulating member **24**, and the second through hole **22** and the second conductive portion **120** may be formed in the composite member **23**.

The composite member **23** may be formed to contact the first adhering layer **31** while entirely facing the display unit **40**. The insulating member **24** may be affixed to at least three peripherally outward sides of the composite member **23** and may partially face the wires and sealing areas **A20**. The insulating member **24** may be equivalent to the composite member **23** in thickness, and may be manufactured through injection molding using plastic.

FIG. **3** and FIG. **4** exemplarily illustrate that the insulating member **24** may contact the entire edges of the composite member **23**, excluding a part of an edge at one long side thereof. However, the shape of the insulating member **24** is not limited to the exemplary drawing, and the shape may be variously modified.

The substrate **10** of the OLED display **100** may be formed with glass or a polymer resin having a small thermal expansion coefficient, since the substrate **10** may experience the thermal treatment processes several times during the forming of the driving circuit and the organic light emitting element thereon. The composite member **23** may be provided to have a thermal expansion coefficient that is similar to that of the substrate **10** by controlling the content of the carbon fiber and the content of the resin.

Thus, when the substrate **10** and the sealing substrate **20** are sealed to each other by hardening the first and the second adhering layer **31** and **32** and the conductive adhering layer **33** at high temperature, torsion of the two substrates **10** and **20** due to the thermal expansion coefficient difference therebetween may be avoided, and a bending problem may be avoided in the environment reliability test after the sealing.

The composite member **23** may have conductivity due to the presence of the carbon fiber. If the sealing substrate **20** were to be formed of only the composite member **23** and the first and second conductive portions **110** and **120** were to be directly formed at the surface of the composite member **23**, the first conductive portion **110** and the second conductive portion **120** might be short-circuited by the composite member **23**. Thus, additional insulating processes such as forming an insulating film at the surface of the composite member **23** and side walls of the first and second through holes **21** and **22** could be required before forming the first and second conductive portions **110** and **120** on the composite member **23**.

However, in the OLED display of the first exemplary embodiment, the sealing substrate **20** is divided into the composite member **23** and the insulating member **24** and the first through hole **21**, and the first conductive portion **110** are formed in the insulating member **24** so that the first conductive portion **110** and the second conductive portion **120** can be insulated from each other without forming an additional insulator such as an insulating film. The detailed structure and constituent material of composite member **23** will be described below in detailed.

Referring to FIG. **5**, the first conductive portion **110** may include a first inner layer **111** formed in the inner surface of the insulating member **24**, a first connection portion **112** that extends through or fills the first through hole **21** while contacting the first inner layer **111**, and a first outer layer **113** formed at the outer side of the insulating member **24** while contacting the first connection portion **112**.

Referring to FIG. **7**, the second conductive portion **120** may include a second inner layer **121** formed at the inner surface of the composite member **23**, a second connection portion **122** that extends through or fills the second through hole **22** while contacting the second inner layer **121**, and a second outer layer **123** formed at the outer surface of the composite member **23** while contacting the second connection portion **122**.

The second conductive portion **120** may be directly formed on the composite member **23** so that the composite member **23** and the second conductive portion **120** are conductive to each other. The insulating member **24** may be insulated from the composite member **23** so that the first conductive portion **110** formed on the insulating member **24** is not short-circuited with the second conductive portion **120**. The first through hole **21** and the second through hole **22** may be formed at a location facing the wires and the sealing areas **A20** of the substrate **10**.

The second inner layer **121** may be formed in a size that covers the display unit **40** and contacts the first adhering layer **31**. The second inner layer **121** may be formed of a metal film having low resistance and an excellent moisture and oxygen interception effect, such as an aluminum film, an aluminum alloy film, a copper film, or a copper alloy film. In addition, the second inner layer **121** may be formed with a metal foil including aluminum or copper.

The second inner layer **121** may be attached to the first adhering layer **31** to cover the display unit **40** peripherally inward from the first adhering layer **31** for protection. The second inner layer may intercept moisture and oxygen entering from the outside to the display unit **40**. The external moisture and oxygen may be intercepted by the composite member **23** having a dense structure and then intercepted by the second inner layer **121**. Thus, the composite member **23** provided with the second inner layer **121** may provide airtightness comparable to a glass substrate.

The second inner layer **121** may include a first extension portion **124** toward the edge of the composite member **23** to be in contact with the second connection portions **122**, and may include a plurality of second extension portions **125** (FIG. **3**) at the inner side of the insulating member **24** so as to face the second pad **36** of the substrate **10** such that the second inner layer **121** contacts the conductive adhering layer **33**. Thus, the second pad **36** of the substrate **10** may be electrically connected with the second inner layer **121** through the conductive adhering layer **33** and the second extension portion **125**.

The first inner layer **111** may be formed to contact the conductive adhering layer **33** between the second extension portions **125** of the second inner layer **121**. The first inner layer **111** may be formed in plural, for example, as plural segments isolated for each other, each overlapping one or more of the first pads **35**, interposing the conductive adhering layer **33** therebetween. Thus, the first pad **35** of the substrate **10** is electrically connected with the first inner layer **111** through the conductive adhering layer **33**. The first inner layer **111** may be formed with a material that is the same as that of the second inner layer **121**.

The first outer layer **113** may overlap all of the plurality of first inner layers **111** at the outer side of the insulating member **24**, and the second outer layer **123** may be formed at the edge of the long side of the composite member **23** where the second through hole **22** is formed. The first outer layer **113** may be formed at the entire edge of the insulating member **24**.

An external access terminal (not shown) may be attached to the first outer layer **113** and the second outer layer **123**. Thus, the first outer layer **113** may receive the first electric signal of

the first common power line **41** from the external access terminal and transmit the signal to the first inner layer **111**, and the second outer layer **123** may receive the second electric signal of the common electrode **42** from the external access terminal and transmit the signal to the second inner layer **121**.

At least one of the width and thickness of the first outer layer **113** may be greater than that of the first inner layer **111**, and the second outer layer **123** may be thicker than the second inner layer **121**. The first inner layer **111** and the second inner layer **121** may have the same thickness and the first outer layer **113** and the second outer layer **123** may have the same thickness to thereby prevent occurrence of stepped portions during the sealing process of the substrate **10** and the sealing substrate **20**. The above-described structure may be usefully applied to a large-sized OLED display having large current capacity.

FIG. **5** to FIG. **7** illustrate partially enlarged cross-sectional views of the OLED display according to the first exemplary embodiment. FIG. **5** illustrates the first common power line and the first pad in detail, and FIG. **6** illustrates the second common power line and the first pad in detail. In addition, FIG. **7** illustrates the common electrode and the second pad in detail.

Referring to FIG. **5** to FIG. **7**, an organic light emitting element **43** and a driving circuit may be formed in each pixel of the display unit **40**. The driving circuit may be formed of at least two thin film transistors and at least one capacitor. In FIG. **5** to FIG. **7**, one thin film transistor **50** and one organic light emitting element **43** may be formed in the display unit **40**.

The thin film transistor **50** may include a semiconductor layer **51**, a gate electrode **52**, a source electrode **53**, and a drain electrode **54**. The semiconductor layer **51** may be formed as a polycrystalline silicon film, and may include a channel area **511**, a source area **512**, and a drain area **513**. The channel area **511** may be an intrinsic semiconductor not doped with an impurity, and the source area **512** and the drain area **513** may be impurity-doped semiconductors.

The gate electrode **52** may be disposed on the channel area **511** of the semiconductor layer **51**, interposing the gate insulating layer **11** therebetween. The source electrode **53** and the drain electrode **54** may be disposed on the gate electrode **52**, interposing an interlayer insulating layer **12** therebetween, and respectively connected with the source area **512** and the drain area **513** through a contact hole formed in the interlayer insulating layer **12**. A planarization layer **13** may be formed on the source electrode **53** and the drain electrode **54**, and a pixel electrode **44** may be formed on the planarization layer **13**. The pixel electrode **44** may be connected with the drain electrode **54** through a contact hole of the planarization layer **13**.

A pixel definition layer **14** may be formed on the pixel electrode **44** and the planarization layer **13**. The pixel definition layer **14** may partially expose the pixel electrode **44** by forming an opening **141** in each pixel. An organic emission layer **45** may be formed on the exposed pixel electrode **44**, and the common electrode **42** may be formed in the entire area of the display unit **40** to cover the organic emission layer **45** and the pixel definition layer **14**. The pixel electrode **44**, the organic emission layer **45**, and the common electrode **42** form the organic light emitting element **43**.

The pixel electrode **44** may be a hole injection electrode and the common electrode **42** may be an electron injection electrode. In this case, the organic emission layer **45** may be formed of a hole injection layer (HIL), a hole transport layer (HTL), an emission layer, an electron transport layer (ETL),

and an electron injection layer (EIL) that are sequentially stacked from the pixel electrode **44**. Holes and electrons are injected to the organic emission layer **45** from the pixel electrode **44** and the common electrode **42**, and emission of light from the organic emission layer **45** is made when the excitons being the combinations of the injected holes and electrons drop from the excited state to the ground state.

The pixel electrode **44** may be formed as a transreflective conductive layer and the common electrode **42** may be formed as a reflective conductive layer. Light emitted from the organic emission layer **45** is reflected by the common electrode **42** and then emitted to the outside through the substrate **10**. Such a light emission structure is called a rear light emission type. The pixel electrode **44** may be formed of a triple-layered film of ITO/silver (Ag)/ITO, and the common electrode **42** may include one of silver (Ag), aluminum (Al), a silver alloy, and an aluminum alloy.

The first common power line **411** and the second common power line **412** may be formed on the same layer of one of the gate electrode **52**, the source electrode **53**, and the drain electrode **54**. FIG. **5** illustrates that the first common power line **411** is formed on the same layer of the source and drain electrodes **53** and **54** with the same material, and FIG. **6** illustrates that the second common power line **412** is formed on the same layer of the gate electrode **52** with the same material.

Referring to FIG. **5** and FIG. **6**, end portions of the first common power line **411** and the second common power line **412** may be extended to the wire and sealing area **A20** at the peripherally outward side of the display unit **40**. In addition, at least one insulating layer among four insulating layers formed in the display unit **40** may be extended to the wire and sealing area **A20**. The end portion of the first common power line **411** may be covered by the planarization layer **13**, and the end portion of the second common power line **412** may be covered by the interlayer insulating layer **12** and the planarization layer **13**.

The planarization layer **13** may include a second opening **131** to expose the end portion of the first common power line **411**, and a first pad conductive layer **151** may be formed on the planarization layer **13** and electrically connected with the first common power line **411** through the second opening **131**. The first pad **35** disposed in the long side of the substrate **10** may be referred to herein as the first pad conductive layer **151**.

The interlayer insulating layer **12** and planarization layer **13** may include a third opening **16** to expose an end portion of the second common power line **412**, and a second pad conductive layer **152** may be formed on the planarization layer **13** and electrically connected with the second common power line **412** through the third opening **16**. The first pad **35** disposed at the short side of the substrate **10** may be referred to herein as the second pad conductive layer **152**.

The first pad conductive layer **151** and second pad conductive layer **152** may be formed on the same layer of the pixel electrode **44** with same material. Then, an additional patterning process for forming the first and second pad conductive layers **151** and **152** can be omitted, and therefore the manufacturing process can be simplified.

Referring to FIG. **7**, the common electrode **42** may be disposed peripherally inward from the first adhering layer **31** and the second pad **36** may be disposed to extend from a peripherally inward side to a peripherally outward side of the first adhering layer **31** such that the common electrode **42** and the conductive adhering layer **33** are in electrical contact with each other.

The second pad **36** may include a third pad conductive layer **153**, a fourth pad conductive layer **154**, and a fifth pad

conductive layer **155**. The third pad conductive layer **153** may be disposed peripherally inward from the first adhering layer **31**, and may contact the common electrode **42**. The fourth pad conductive layer **154** may be connected to the third pad conductive layer **153** through the fourth opening **132** of the planarization layer **13**, and may extend from a peripherally inward side to a peripherally outward side of the first adhering layer **31**. The fifth pad conductive layer **155** may be disposed between the conductive adhering layer **33** and the planarization layer **13**, and may be connected with the fourth pad conductive layer **154** through a fifth opening **133**.

The third pad conductive layer **153** and the fifth pad conductive layer **155** may be formed on the same layer as the pixel electrode **44** with the same material. In addition, the fourth pad conductive layer **154** may be formed on the same layer as one of the gate electrode **52** and the source and drain electrodes **53** and **54** with the same material. Thus, an additional patterning process for forming the second pad **36** can be omitted, and therefore the manufacturing process can be simplified.

FIG. 7 exemplarily illustrates that the fourth pad conductive layer **154** may be formed on the same layer as the source and drain electrodes **53** and **54**. The detailed structure of the second pad **36** is not limited to the illustrated example, and any structure that places the common electrode **42** and the wire and sealing area **A20** of the display unit **40** into electrical contact with each other may be used.

In the previously stated OLED display **100**, the substrate **10** may be made of transparent glass or transparent plastic. The substrate **10** made of a transparent plastic material may include at least one of polyether sulfone, polyacrylate, polyether imide, polyethylene naphthalate, polyethylene terephthalate, poly phenylene sulfide, polyarylate, polyimide, polycarbonate, cellulose triacetate, and cellulose acetate propionate.

A plurality of processes for forming a plurality of pixels on the substrate **10** may be performed and heat may be applied to the substrate **10** during the processes such that the substrate **10** may expand due to the heat. Expansion of the substrate **10** may reduce durability of the OLED display **100** and density of the display unit **40** and therefore a material having a low thermal expansion coefficient is desirable for the substrate **10**. The substrate **10** made of glass or plastic has a thermal expansion coefficient approximately between  $3 \times 10^{-6}/\text{K}$  to  $4 \times 10^{-6}/\text{K}$ .

FIG. 8 illustrates a partially enlarged top plan view of the composite member of the OLED display of FIG. 1.

Referring to FIG. 8, the composite member **23** may be made of a carbon composite material including a plurality of carbon fibers **26** and resin **25**. The composite member **23** may have a structure in which the carbon fibers **26** are impregnated with the resin **25**. In other words, the resin **25** serves as a base layer that surrounds the carbon fibers **26** to fix them as one layer.

The carbon fibers **26** may have a lower thermal expansion coefficient than the substrate **10**. Particularly, the thermal expansion coefficient in the length direction of the carbon fibers **26** may have a negative (-) value. On the other hand, the resin **25** may have a higher thermal expansion coefficient than the substrate **10**. Thus, the thermal expansion coefficient of the composite member **23** can be controlled by controlling the amount of carbon fibers **26** and the amount of the resin **25**.

When manufacturing the composite member **23** by compounding the carbon fibers **26** and the resin **25**, the thermal expansion coefficient of the composite member **23** may be

controlled to be equivalent or similar to that of the substrate **10** by controlling a ratio of the resin **25** and the carbon fibers **26**.

The carbon fibers **26** do not absorb moisture so that they may increase the waterproofing ability of the composite member **23**. In addition, the composite member **23** including the carbon fibers **26** has excellent mechanical properties so that high mechanical strength may be realized with a small thickness. Thus, the entire thickness of the OLED **100** can be reduced. In addition, the composite member **23** may function to suppress thermal expansion of the first inner layer **111** and the second inner layer **121**.

The plurality of carbon fibers **26** may be arranged to cross each other, and, for example, may be woven with wefts and warps. Although FIG. 8 shows carbon fibers **26** that perpendicularly cross each other, the present embodiments are not limited to the example shown in FIG. 8 and the carbon fibers **26** may cross each other at predetermined angles other than the right angle. According to the configuration described above, the composite member **23** may have a low thermal expansion coefficient throughout the region and the durability of the composite member **23** may be increased.

As an exemplary variation, FIG. 9 illustrates an exploded perspective view of the composite member of the OLED display of FIG. 1.

Referring to FIG. 9, the composite member **230** may be formed of a plurality of layers. For example, the composite member **230** may have a structure formed by stacking the first layer **L10**, a second layer **L20**, a third layer **L30**, and a fourth layer **L40**. Each of the layers **L10**, **L20**, **L30**, and **L40** may include a resin **25** and a plurality of carbon fibers **261**, **262**, **263**, and **264**.

The carbon fibers **261** and **264** of the first layer **L10** and the fourth layer **L40** may be arranged along a first direction, and the carbon fibers **262** and **263** of the second and third layers **L20** and **L30** may be arranged along a second direction. The first direction and the second direction may or may not perpendicularly cross each other. FIG. 9 exemplarily illustrates that the first direction and the second direction perpendicularly cross each other.

The resin **25** may be integrally hardened by pressure-baking such that the first to fourth layers **L10** to **L40** form a single composite member **230**. When the plurality of carbon fibers **261**, **262**, **263**, and **264** are arranged as described above, torsion of the composite member **230** may be suppressed so that planarity of the composite member **230** can be increased.

In order to control the thermal expansion coefficient, an angle formed by an arrangement direction of the carbon fibers **261** and **262** in the first and fourth layers **L10** and **L40** and an arrangement direction of the carbon fibers **262** and **263** of in the second and third layers **L20** and **L30** may be variously set. The thermal expansion coefficient of each of the respective layers **L10**, **L20**, **L30**, and **L40** can be easily controlled by controlling the amount of the resin **25** and the carbon fibers **261**, **262**, **263**, and **264** included in the respective layers **L10**, **L20**, **L30**, and **L40**.

The OLED display **100** of the first exemplary embodiment includes the first conductive portion **110** and the second conductive portion **120** in the sealing substrate **20** to apply the corresponding electric signal to the common power line **41** and the common electrode **42**. In this case, since the sealing substrate **20** has a structure that includes both the composite member **23** and the insulating member **24** instead of only the composite member **23**, an insulating film forming process for insulation between the first conductive portion **110** and the second conductive portion **120** can be omitted.

In addition, since it is not easy to form holes in the composite member **23** including solid carbon fibers **26**, the sealing substrate **20** can be easily manufactured by forming the first through holes **21**, which may be more numerous than the second through holes **22**, in the insulating member **24**. The first through holes **21** may be formed together when the insulating member **24** is formed by injection-molding plastic, or the holes of the insulating member **24** may be easily formed after the insulating member **24** is formed.

FIG. **10** illustrates a schematic cross-sectional view of an OLED display according to another exemplary embodiment, and FIG. **11** and FIG. **12** illustrate plan views of the inner and outer sides, respectively, of a sealing substrate of the OLED display of FIG. **10**.

Referring to FIG. **10** to FIG. **12**, an OLED display **200** according to the exemplary embodiment of FIG. **10** may have the same structure as the exemplary embodiment of FIG. **1**, except that an insulating member **241** is affixed to surround the entire side surface of a composite member **231** and first and second through holes **21** and **22** are formed in the insulating member **241**. Like reference numerals designate like elements of the exemplary embodiment of FIG. **1**.

A second inner layer **121** of a second conductive portion **120** may include a first extension portion **124** that extends in the inner side of the insulating member **241** to be in contact with a second connection portion **122** that extends through or fills the second through hole **22**. In addition, the second inner layer **121** includes a second pad **36** formed in a substrate **10** and a plurality of second extension portions **125** that extend to the inner side of the insulating member **241**. The second outer layer **123** is disposed at the outer side of the insulating member **241**.

The first and second extension portions **124** and **125** are formed through the composite member **231** and the insulating member **241**, but the first and second extension portions **124** and **125** are not short-circuited with a first conductive portion **110** because they are spaced apart from a first inner layer **111** on the insulating member **241**.

When a second inner layer **121** is formed of a metal foil, the second inner layer **121** may be fixed to the composite member **231** after forming an oxide film by anodizing at one side of the second inner layer **121**, facing the composite member **231**. In this case, since the oxide film functions as an insulator, the second inner layer **121** is insulated from the composite member **231** and may be rigidly adhered to the composite member **231** by roughness of the oxide film.

FIG. **13** illustrates a schematic cross-sectional view of an OLED display according to another exemplary embodiment.

Referring to FIG. **13**, an OLED display **300** according to this exemplary embodiment may have the same overall structure as the previously described exemplary embodiments, except that a protrusion-groove combination structure is formed at a peripherally outward side surface of a composite member **232** and a peripherally inward side surface of an insulating member **242**. FIG. **13** illustrates that the protrusion-groove combination structure may be formed in the structure of the exemplary embodiment, of FIG. **10** and like reference numerals designate like elements of the exemplary embodiment of FIG. **10**.

A protrusion **271** formed in the shape of “v” may protrude toward an insulating member **242** at the peripherally outward side surface of the composite member **232**, and a groove **272** may be formed facing the protrusion **272** at a peripherally inward surface of the insulating member **242** for receiving the protrusion **271**. The protrusion **271** may be formed by grinding or cutting an edge of the composite member **232**. The

shape of the protrusion **271** and the shape of the groove **272** are not restrictive, and any protrusion-groove combination structure may be used.

A sealing substrate **20** may be manufactured through two steps. That is, the composite member **232** including the resin **25** and the carbon fibers **26** may be manufactured by hot-pressing the composite member **232** and then the composite member **232** may be inserted to an injection-mold. The insulating member **242** may be injection-molded by injecting a resin to the edge portion of the composite member **232** in the injection mold. Alternatively, the sealing substrate **20** may be manufactured by pressing the composite member **232** using an upper mold of the injection mold and injection-molding the insulating member **242** by injecting a resin to the edge portion of the composite member **232** in the injection mold.

A combination structure of a protrusion **271** and a groove **272** of the composite member **232** and the insulating member **242** may enable the insulating member **242** to be more effectively attached to the composite member **232**, thereby increasing the bonding force of the composite member **232** and the insulating member **24**. Thus, the composite member **232** and the insulating member **242** may not easily separate after the sealing substrate **20** is manufactured.

FIG. **14** illustrates a schematic cross-sectional view of an OLED display according to another exemplary embodiment.

Referring to FIG. **14**, an OLED display **400** according to this exemplary embodiment may have the same overall structure as the previously described exemplary embodiments, except that an insulating plate **233** covering the outer side of a composite member **232** is further formed. FIG. **14** illustrates that an insulating plate **233** further formed in the structure of the exemplary embodiment of FIG. **13**, and like reference numerals designate like elements of the exemplary embodiment of FIG. **13**.

The insulating plate **233** may be integrally formed with an insulating member **243** when manufacturing the insulating member **243** by injection molding. The insulating plate **233** may be wholly attached to the outer surface of the composite member **232** to increase the bonding force between the insulating member **243** and the composite member **232** and may insulate the outer surface of the composite member **232**. The insulating plate **233** may be thin in order not to increase the thermal expansion coefficient of a sealing substrate **20**. For example, the thickness of the insulating plate **233** may be set to be less than 20% to 30% of the thickness of the composite member **232**.

FIG. **15** illustrates a top plan view illustrating an outer surface of a sealing substrate of an OLED display according to another exemplary embodiment.

Referring to FIG. **15**, an OLED display **500** according to this exemplary embodiment may have the same overall structure as the previously described exemplary embodiments, except that gear-teeth-shaped protruding portions **273** and recess portions **274** are formed along an edge of a composite member **234** at a peripherally outward side surface of the composite member **234** and an peripherally inward side surface of an insulating plate **244**.

FIG. **15** illustrates that the protruding portion **273** and the recess portion **274** may be formed in the sealing substrate structure of the exemplary embodiment of FIG. **10**, and illustration of first and second conductive portions **110** and **120** is omitted. Like reference numerals designate like elements of the exemplary embodiment of FIG. **10**.

A plurality of protruding portions **273** may be formed along the edge of the composite member **234** at the peripherally outward side surface thereof, and the protruding portions **273** may be spaced apart from each other. In addition, a

plurality of recess portions 274 that receive the protruding portions 273 may be formed at a peripherally inward surface of the insulating member 244, facing the plurality of protruding portions 273. The shape of the protruding portions 273 and the shape of the recess portions 274 are not restrictive. Any structure that can combine the protruding portion and the recess portion may be used.

The protruding portions 273 and the recess portions 274 enlarge a contact area of the composite member 234 and the insulating member 244 to increase the bonding force between the composite member 234 and the insulating member 244. Thus, the composite member 234 and the insulating member 244 may not easily separate after the sealing substrate 20 is manufactured.

FIG. 16 is a schematic cross-sectional view of an OLED display according to another exemplary embodiment.

Referring to FIG. 16, an OLED display 600 according to this exemplary embodiment may have the same overall structure as the previously described exemplary embodiments, except that a protection portion 29 is further formed to cover side surfaces of a second adhering layer 32 and a substrate 10 for protection. FIG. 16 illustrates that the protection portion 29 may be formed in the structure of the exemplary embodiment of FIG. 10, and like reference numerals designate like elements of the exemplary embodiment of FIG. 10.

The protection portion 29 may be integrally formed with an insulating member 245, and may be disposed perpendicularly to the insulating member 245. The protection portion 29 may be formed at three edges of the insulating member 245 that are not facing a pad area A30. The protection portion 29 may protect a substrate 10 made of a fragile material such as glass, and may function to increase the bending strength of a composite member 235. Such a protection portion 29 may be formed together with the insulating member 245 when manufacturing the insulating member by injection molding.

In the OLED displays 100 to 600 of the exemplary embodiments described herein, the insulating members 24, 241, 242, 243, 244, and 245 may be made of plastic that includes a negative thermal expansion filler.

Typical plastic has a high thermal expansion coefficient compared to a composite member 23 including a carbon fiber 26. When an insulating member 24 is made of the typical plastic, a stress may be generated between the integrally combined composite member 23 and the insulating member 24 if the peripheral temperature of the OLED display varies by a large difference, thereby causing deformation or separation.

Thus, the insulation members 24, 241, 242, 243, 244, and 245 may be made of plastic into which the negative thermal expansion filler is saturated so that a thermal expansion coefficient difference with the composite member 23 can be reduced. The negative thermal expansion filler may include at least one of tungsten zirconium ( $ZrW_2O_8$ ),  $AM_2O_8$  (where, A is Zr or Hf and M is Mo or W),  $ZrV_2O_7$ , and  $A_2(MO_4)_3$  (where, A is Zr or Hf and M is Mo or W).

FIG. 17 is a schematic cross-sectional view of an OLED display according to another exemplary embodiment and FIG. 18 is a partially enlarged view of the OLED display of FIG. 17.

Referring to FIG. 17 and FIG. 18, an OLED display 700 according to the this exemplary embodiment may have the same overall structure as any one of the previously described exemplary embodiments, except that a second pad is omitted in the OLED display 700 and a second inner layer 121 formed in a sealing substrate 20 contacts a common electrode 420. The OLED display illustrated in FIG. 17 may be based on the OLED display of the exemplary embodiment of FIG. 1 and a

basic structure, and like reference numerals designate like elements of the exemplary embodiments of FIGS. 1 and 10.

In a display unit 40, the common electrode 420 may form a protrusion and depression structure. The common electrode 420 may include plurality of protruding portions 421 that are sealed to the second inner layer 121 formed in the sealing substrate 20. The common electrode 420 may be directly connected with the second conductive portion 120 without passing through a conductive adhering layer 33 and may receive a second electric signal therefrom.

The protrusion and depression structure of the common electrode 420 can be formed by providing a spacer 17. For example, a plurality of spacers 17 may be formed on a pixel definition layer 14, and the common electrode 420 may be formed throughout the entire area of the display unit 40 while covering the plurality of spacers 17. The common electrode 420 may be sealed to the second inner layer 121 when sealing the substrate 10 and the sealing substrate 20 by pressing and may be electrically connected with the second conductive portion 120.

In the OLED display 700 of the exemplary embodiment of FIGS. 17 and 18, only the first pad 35 is disposed in a wire and sealing area A20 for applying a first electric signal of a common power line 41. In addition, a second inner layer formed in the sealing substrate with a plurality of second extension portions extended toward a second pad is not provided as in the exemplary embodiment of FIG. 1.

By way of summation and review, since a function of a display unit including a plurality of organic light emitting elements may deteriorate when the display unit is exposed to moisture and oxygen, a technique for sealing the display unit to suppress penetration of external moisture and oxygen is desired. The described technology has been made in an effort to provide a display device in which a sealing function of a display unit and an organic light emitting diode (OLED) display is improved. The OLED display according to the described embodiments may enhance the sealing function of the display unit, may increase luminance uniformity of the screen while providing a large-sized display unit, and may simplify an entire structure and manufacturing process by reducing the number of parts. In addition, the first conductive portion and the second conductive portion can be insulated from each other without providing an insulating means such as an insulating layer to the sealing substrate.

Exemplary embodiments have been disclosed herein, and although specific terms are employed, they are used and are to be interpreted in a generic and descriptive sense only and not for purpose of limitation. Accordingly, it will be understood by those of ordinary skill in the art that various changes in form and details may be made without departing from the spirit and scope as set forth in the following claims.

What is claimed is:

1. A display device, comprising:

a display substrate;

a display unit disposed on the display substrate;

a sealing substrate affixed to the display substrate by an adhering layer located outside an outer periphery of the display unit, the sealing substrate located outside of a display area of the display substrate, the sealing substrate including a composite member including a resin and a plurality of carbon fibers and an insulating member affixed to the composite member, the insulating member including a plurality of first through holes through the insulating member;

a metal film disposed at one side of the sealing substrate, facing the display substrate; and

a conductive connection portion contacting the metal film through a plurality of second through holes through the sealing substrate;

wherein the insulating member is affixed to the composite member at a peripherally outward side of at least three peripheral edges of the composite member, and

wherein the adhering layer includes a first non-conductive adhering layer located outside the outer periphery of the display unit, a second non-conductive adhering layer located peripherally outward from the first non-conductive adhering layer, and a conductive adhering layer between the first non-conductive adhering layer and the second non-conductive adhering layer.

2. The display device as claimed in claim 1, wherein the carbon fibers cross each other in the resin.

3. The display device as claimed in claim 1, wherein the composite member includes a plurality of layers, each of the plurality of layers including a resin and a plurality of carbon fibers, wherein a plurality of carbon fibers arranged in at least one of the plurality of layers and a plurality of carbon fibers arranged in at least another layer among the plurality of layers cross each other.

4. The display device as claimed in claim 1, further comprising:

a first conductive portion extending between inner and outer sides of the insulating member through the plurality of first through holes and receiving a first electric signal; and

a second conductive portion extending between inner and outer sides of the composite member through the plurality of second through holes and receiving a second electric signal.

5. The display device as claimed in claim 1, wherein the insulating member is affixed to the composite member at a peripherally outward side of all peripheral edges of the composite member.

6. The display device as claimed in claim 5, further comprising:

a first conductive portion extending between inner and outer sides of the insulating member through the plurality of first through holes and receiving a first electric signal; and

a second conductive portion extending between an inner side of the insulating member, an inner side of the composite member, and an outer side of the insulating member through the plurality of second through holes and receiving a second electric signal.

7. The display device as claimed in claim 1, wherein the composite member includes a protrusion at a side surface that faces the insulating member, and the insulating member includes a groove receiving the protrusion.

8. The display device as claimed in claim 1, wherein the composite member includes a plurality of protruding portions spaced apart from each other at a side surface facing the insulating member, and the insulating member includes a plurality of recess portions receiving the protruding portions.

9. The display device as claimed in claim 1, wherein the insulating member further includes an insulating plate covering an external surface of the composite member.

10. The display device of claim 1, wherein the insulating member further includes a protection portion that protectively covers the adhering layer and a side surface of the display substrate.

11. The display device as claimed in claim 1, wherein the insulating member is a plastic injection molded material.

12. The display device as claimed in claim 11, wherein the insulating member includes a negative thermal expansion filler.

13. The display device as claimed in claim 1, wherein the metal film includes at least one of an aluminum film, an aluminum alloy film, a copper film, and a copper alloy film.

14. An organic light emitting diode (OLED) display, comprising:

a display substrate;

a display unit disposed on the display substrate and including a common power line and a common electrode;

a sealing substrate affixed to the display substrate by at least one adhering layer located outside an outer periphery of the display unit, the sealing substrate located outside of a display area of the display substrate, the sealing substrate including first and second through holes through the sealing substrate;

a first conductive portion disposed on inner and outer sides of the sealing substrate and extending through the first through holes, the first conductive portion supplying a first electric signal to the common power line; and

a second conductive portion disposed on the inner and outer sides of the sealing substrate and extending through the second through holes, the second conductive portion supplying a second electric signal to the common electrode,

wherein the sealing substrate includes,

a composite member including a resin and a plurality of carbon fibers, and

an insulating member attached to the composite member and including at least one through hole among the first and second through holes;

wherein the insulating member is attached to the composite member at peripherally outward sides of at least three peripheral edges of the composite member, and wherein the insulating member includes the first through holes, and the composite member includes the second through holes, and

wherein the at least one adhering layer includes a first non-conductive adhering layer located outside the outer periphery of the display unit, a second non-conductive adhering layer located peripherally outward from the first non-conductive adhering layer, and a conductive adhering layer between the first non-conductive adhering layer and the second non-conductive adhering layer.

15. The OLED display as claimed in claim 14, further comprising:

a pad unit disposed peripherally outward from the display unit, and including a first pad connected with the common power line and a second pad connected with the common electrode; and

the conductive adhering layer is disposed between the first pad and the first conductive portion and between the second pad and the second conductive portion.

16. The OLED display as claimed in claim 15, wherein the common power line includes a first common power line and a second common power line that cross each other, and wherein the pad unit includes a plurality of the first pad and the second pad iteratively alternated along one direction of the display substrate.

17. The OLED display as claimed in claim 15, wherein the conductive adhering layer is electrically conductive in the thickness direction and electrically insulating in directions other than the thickness direction.

18. The OLED display as claimed in claim 14, further comprising a first pad disposed at an outer side of the display unit and the conductive adhering layer is disposed between

19

the first pad and the first conductive portion, and wherein the second conductive portion is directly attached to the common electrode.

19. The OLED display as claimed in claim 18, further comprising a plurality of spacers disposed at a lower portion of the common electrode,

wherein the common electrode includes protruding portions corresponding to the spacers and contacting the second conductive portion.

20. The OLED display as claimed in claim 14, wherein the first conductive portion includes a first inner layer disposed at the inner side of the insulating member, a first connection portion extending through the first through hole, and a first outer layer disposed at the outer side of the insulating member, and wherein the second conductive portion includes a second inner layer formed at the inner side of the composite member, a second connection portion filled in the second through hole, and a second outer layer formed at the outer side of the composite member.

21. The OLED display as claimed in claim 14, wherein the insulating member is attached to the composite member at a peripherally outward side of the edges of the composite member, and wherein the insulating member includes the first and second through holes.

22. The OLED display as claimed in claim 21, wherein the first conductive portion includes a first inner layer at the inner side of the insulating member, a first connection portion that fills the first through hole, and a first outer layer at the outer side of the insulating member, and the second conductive portion includes a second inner layer at the inner side of the insulating member and the inner side of the composite mem-

20

ber, a second connection portion that fills the second through hole, and a second outer layer at the outer side of the insulating member.

23. The OLED display as claimed in claim 22, wherein the second inner layer includes a metal foil having an oxide film formed by anodizing at one side thereof, facing the composite member.

24. The OLED display as claimed in claim 14, wherein the insulating member is made of a plastic injection molded material.

25. The OLED display as claimed in claim 24, wherein the insulating member includes a negative thermal expansion filler.

26. The OLED display as claimed in claim 24, wherein the composite member includes a protrusion at a side surface thereof, facing the insulating member, and the insulating member includes a groove that receives the protrusion.

27. The OLED display as claimed in claim 24, wherein the composite member includes a plurality of protruding portions spaced apart from each other at a side surface, facing the insulating member and the insulating member includes recess portions receiving the protruding portions.

28. The OLED display as claimed in claim 24, wherein the insulating member further includes an insulating plate covering an external surface of the composite member.

29. The OLED display as claimed in claim 24, wherein the insulating member further includes a protection portion covering the adhering layer and the display substrate along the thickness direction.

\* \* \* \* \*

专利名称(译)	显示装置和有机发光二极管显示器		
公开(公告)号	<a href="#">US9281494</a>	公开(公告)日	2016-03-08
申请号	US13/064721	申请日	2011-04-11
[标]申请(专利权)人(译)	LEE CHOONG HO NAM HYUN KIE 李贞旻		
申请(专利权)人(译)	LEE CHOONG HO NAM HYUN KIE 李政闵		
当前申请(专利权)人(译)	三星DISPLAY CO. , LTD.		
[标]发明人	LEE CHOONG HO NAM KIE HYUN LEE JUNG MIN		
发明人	LEE, CHOONG-HO NAM, KIE HYUN LEE, JUNG-MIN		
IPC分类号	H01L51/52 H01L27/32		
CPC分类号	H01L51/5237 H01L27/3276 H01L51/5246 H01L51/524 H01L51/5243		
优先权	1020100073513 2010-07-29 KR		
其他公开文献	US20120026074A1		
外部链接	<a href="#">Espacenet</a> <a href="#">USPTO</a>		

摘要(译)

一种显示装置，包括：显示基板；显示单元形成在显示基板上，密封基板通过围绕显示单元的粘附层固定到显示基板上。密封基板包括复合构件和绝缘构件，复合构件包括树脂和多个碳纤维，绝缘构件附接到复合构件。绝缘构件包括通孔。金属膜设置在密封基板的一侧，面向显示基板；导电连接部分通过通孔与金属膜接触。

